

Article number: 20028397

Description: E+G
Spring plunger GN 610-2,6-8-H

Measures

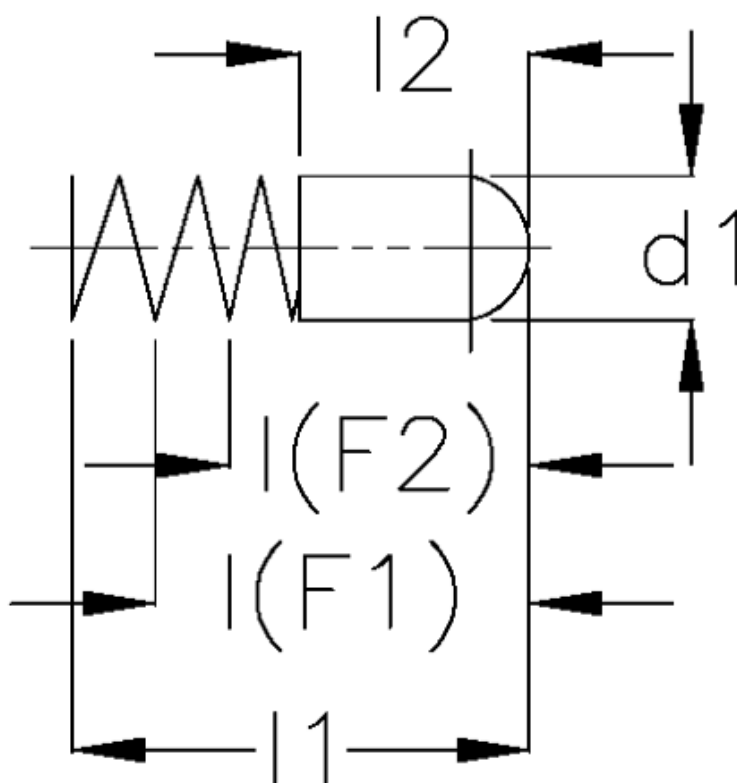

d_1	= 2.6
$I(F1)$	= 6.5
$I(F2)$	= 5.2
I_1	= 8
I_2	= 3.8
Spring pressure (F1) N	= 1.1
Spring pressure (F2) N	= 2.0